

Zone	Revision	Description
1		See CRE ET-233 and ET-286
2		See CRE ET-1140 (IDOM) + ET-1142 (ESO)
3		ESO-ACe-TM283/ET-838 (ACe), ET-1340 (HARMONI), ET-1341 (MICADO), ET-1342 (METIS), ET-1343 (MORFEO), ET-1350 (IDOM), ET-1351 (CM+POS), ET-1356 (ANDES), ET-1357 (MOSAIC), ET-1190 (ESO)

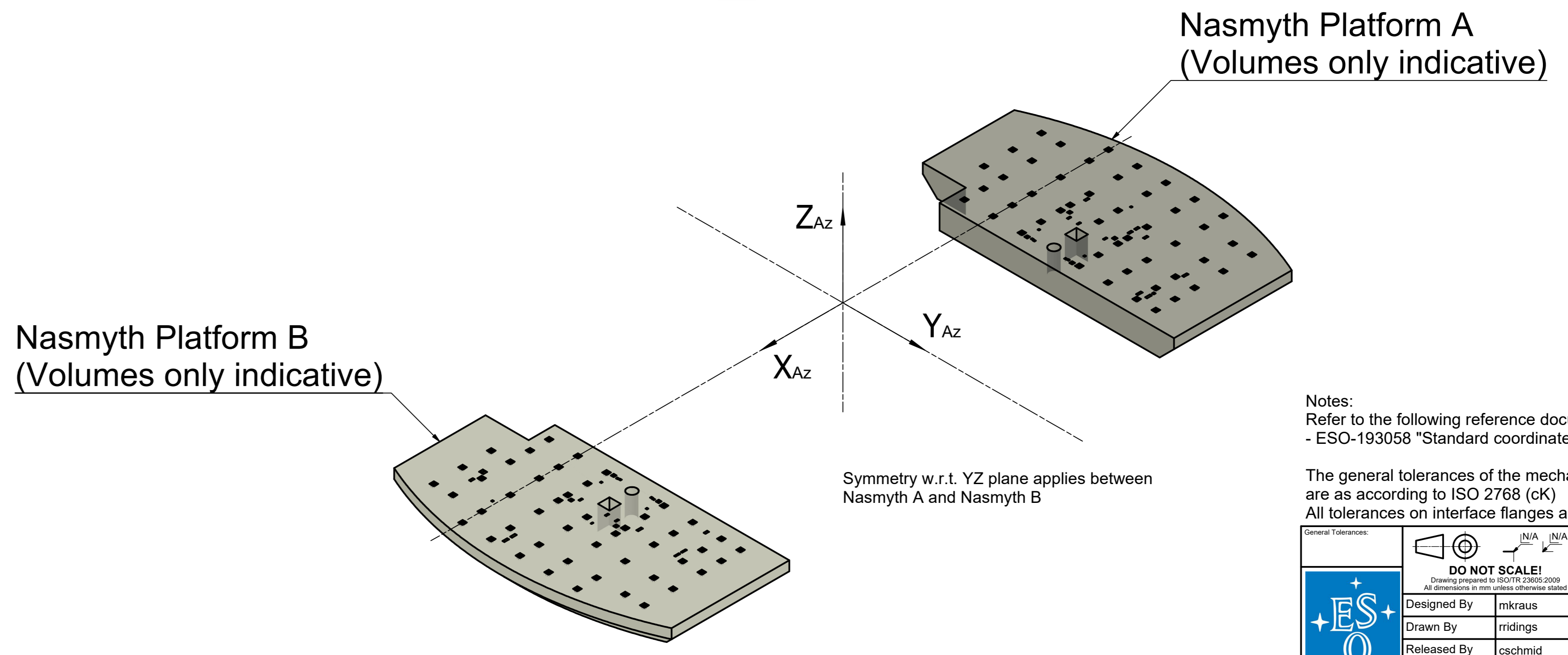
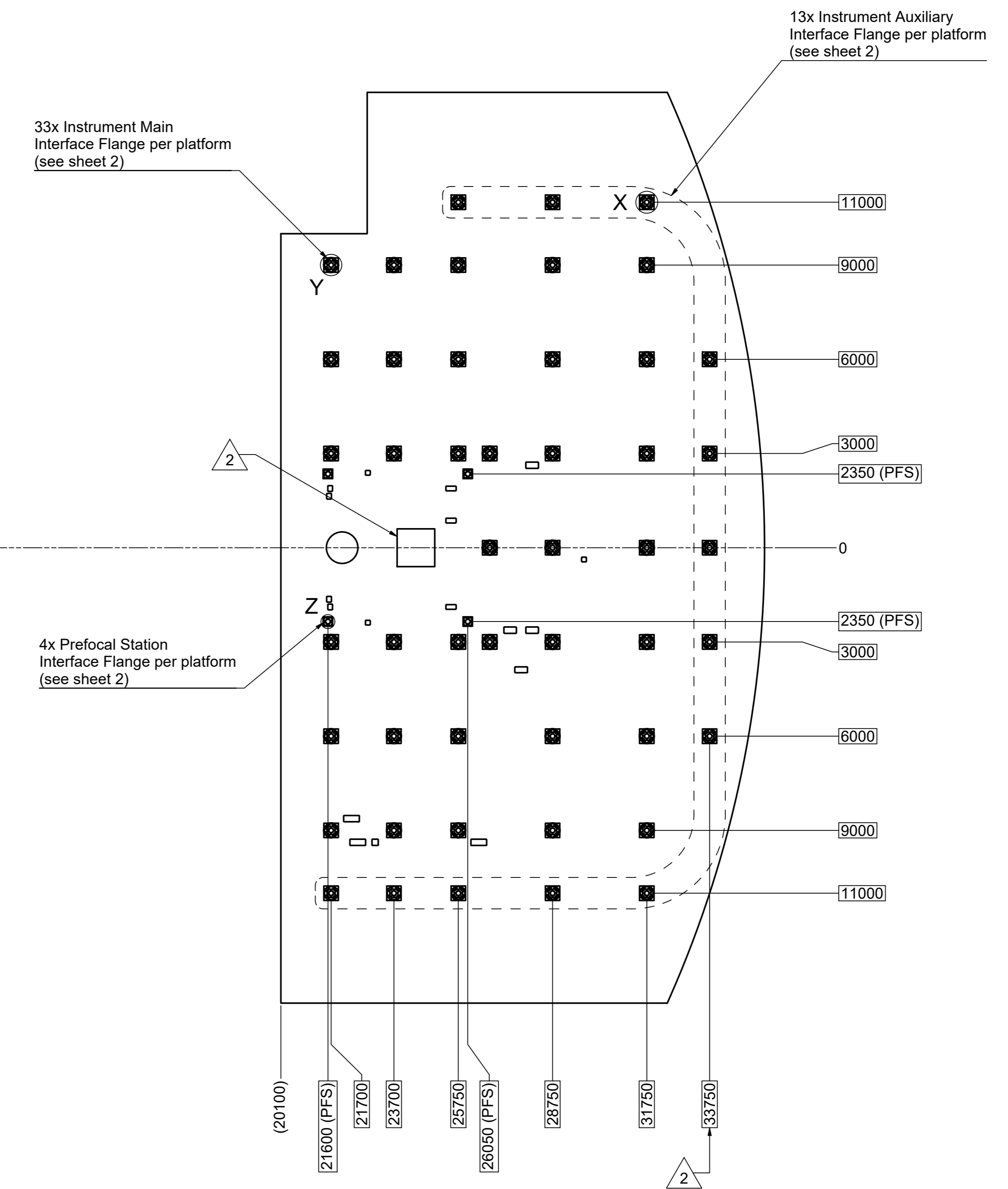
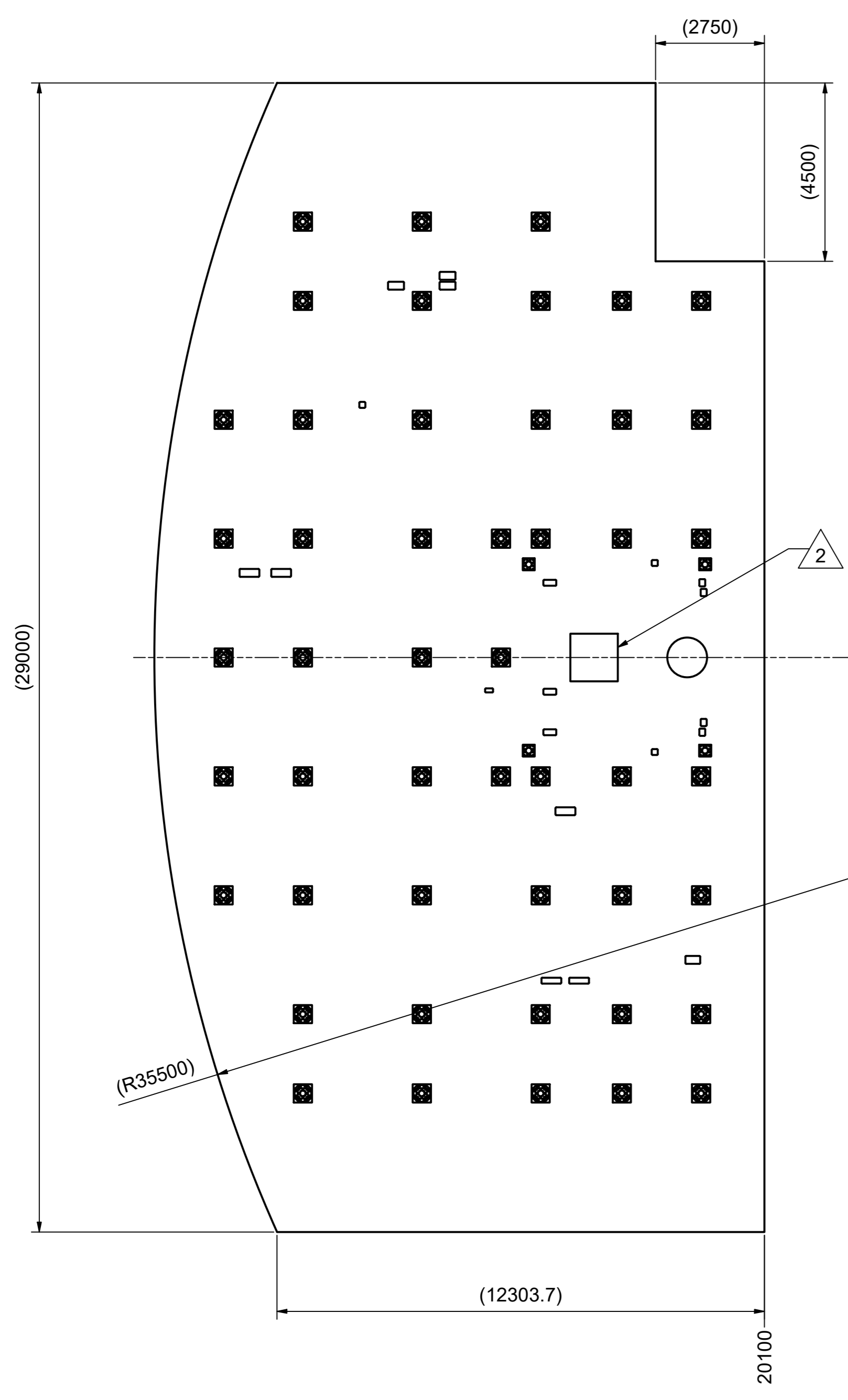
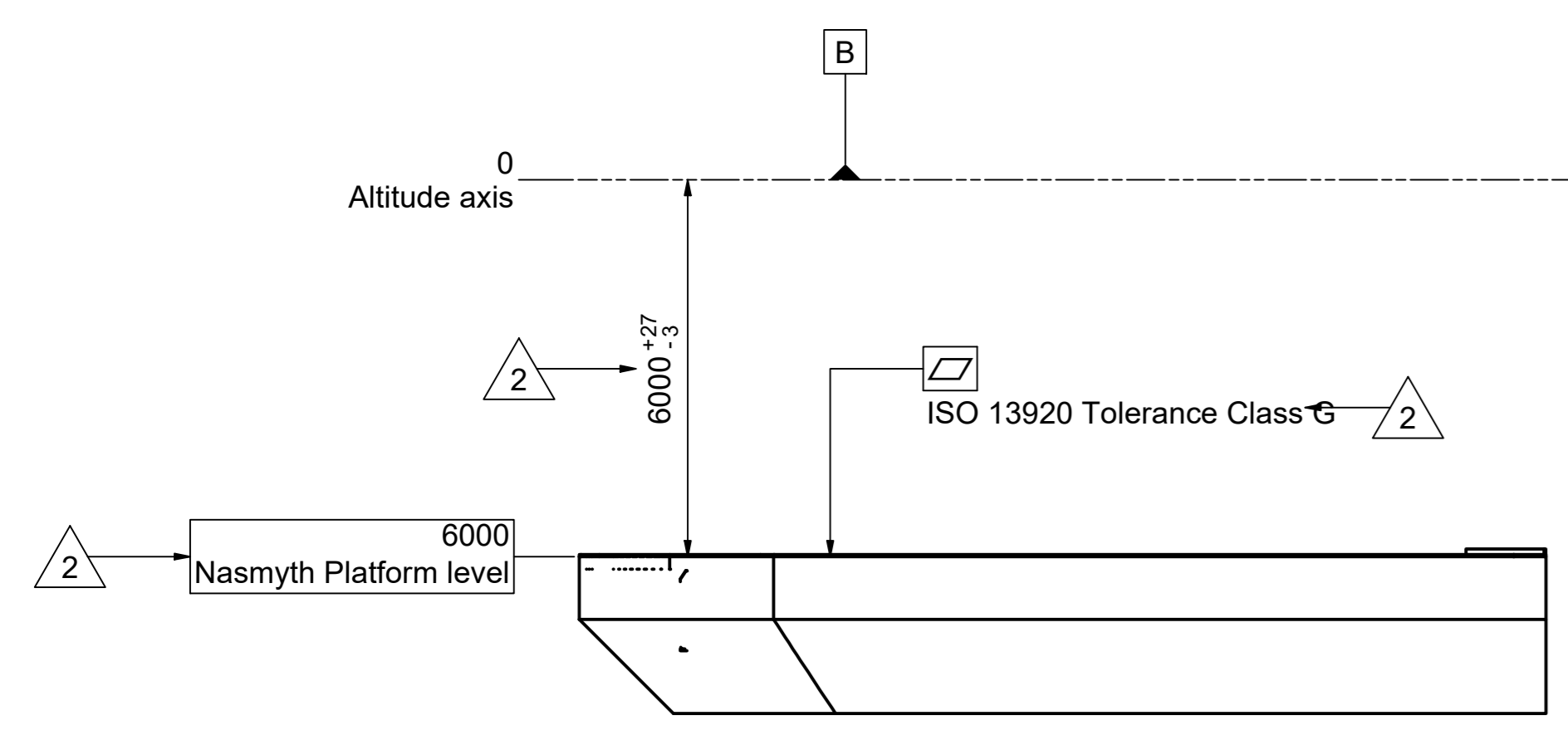

Notes:  
Refer to the following reference document:  
- ESO-193058 "Standard coordinate systems and basic conventions"

The general tolerances of the mechanical interfaces of the Telescope Main Structure are as according to ISO 2768 (ck)  
All tolerances on interface flanges apply to the Main Structure side

General Tolerances	ISO 2768 (ck)	Material	Not applicable	Max.	N/A
Surface Treatment	Not applicable	Other Treatment	Not applicable		
DO NOT SCALE!		File Additional Information			
Designed By	mkraus	<b>Nasmyth Platform Interfaces</b>			
Drawn By	mfnding	For Prefocal Station and Instruments			
Released By	cschmid	Production No.	E-ELT	Scale	1 : 100
Project Manager	E-ELT	Revision No.	100	Sheet	1 / 4
State	RELEASED	Date	2023-11-21	Document ID	CAD-135139
					3

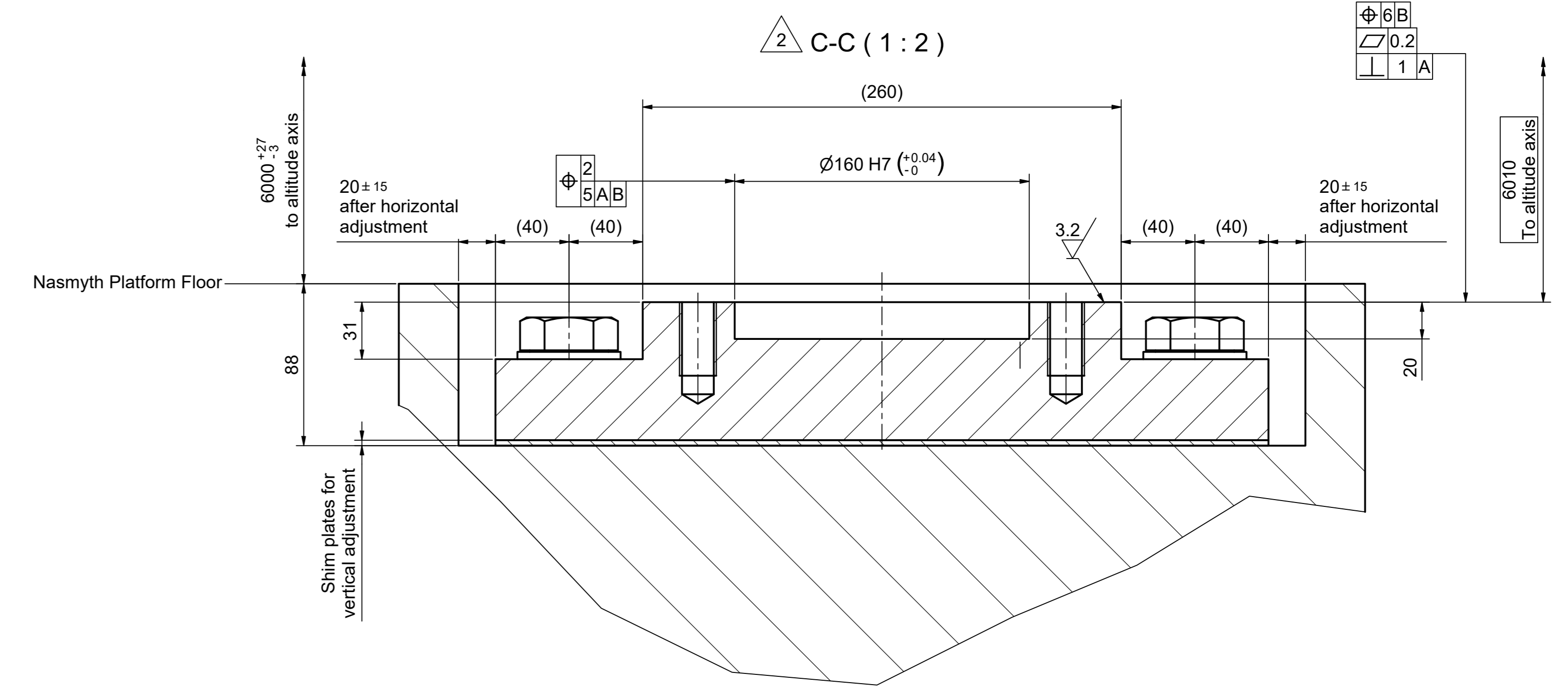
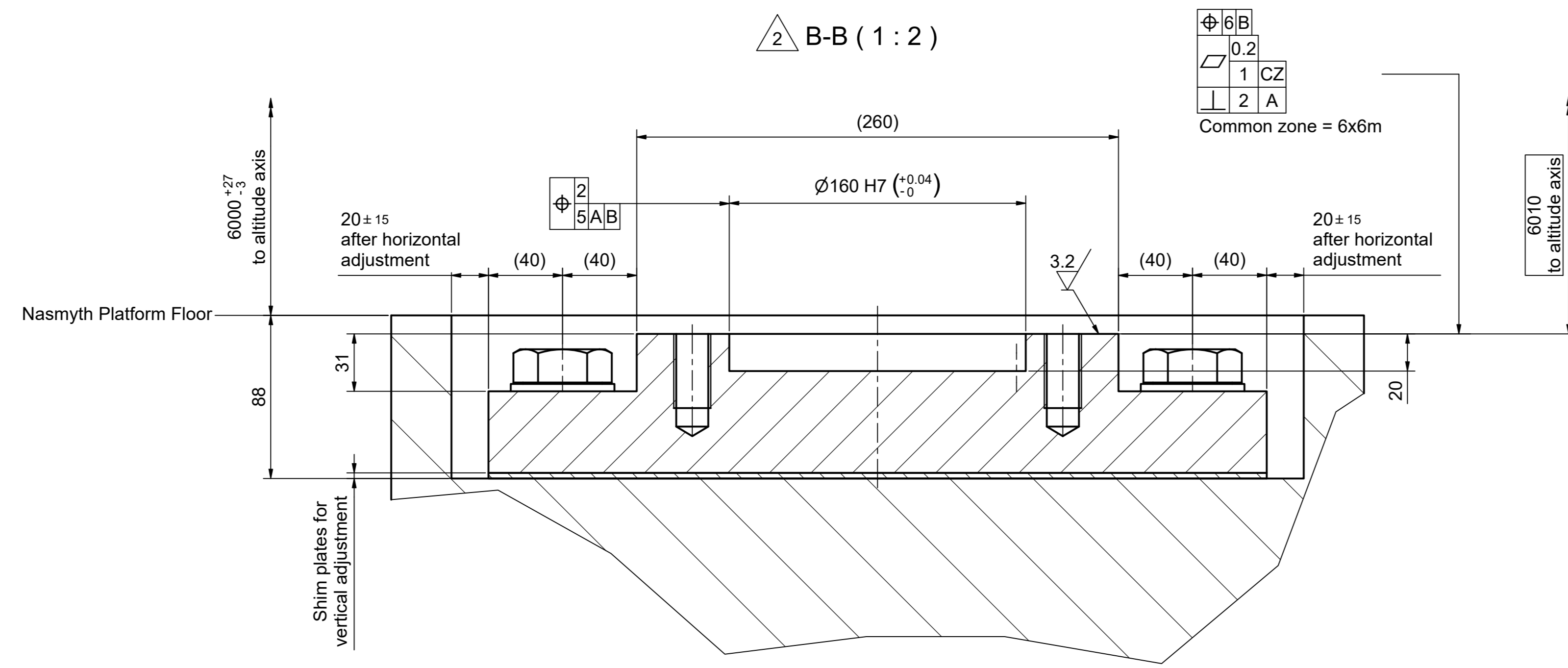

**A-A (1:2)**

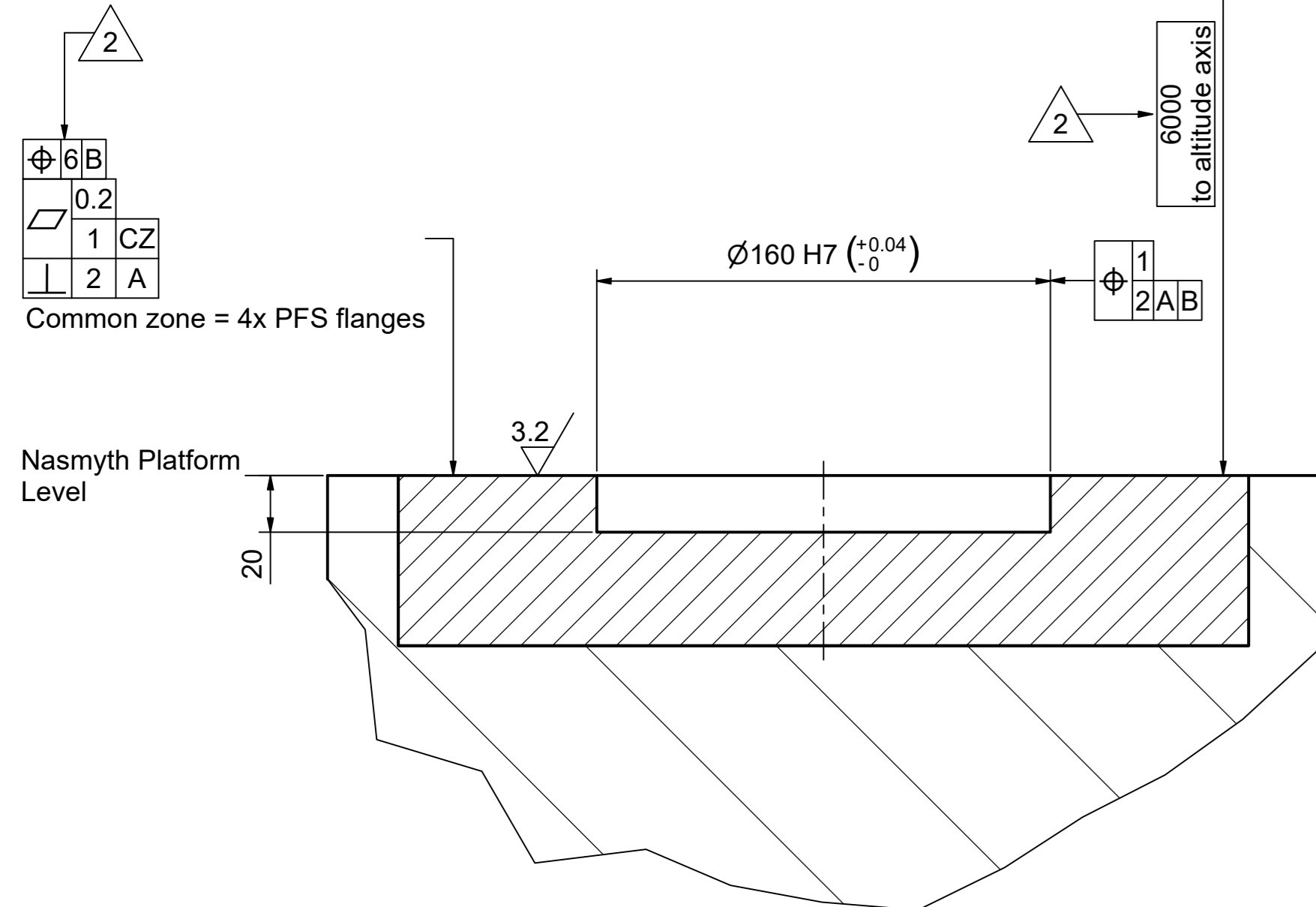

**Y (1:2) Instrument Main Interface Flange**

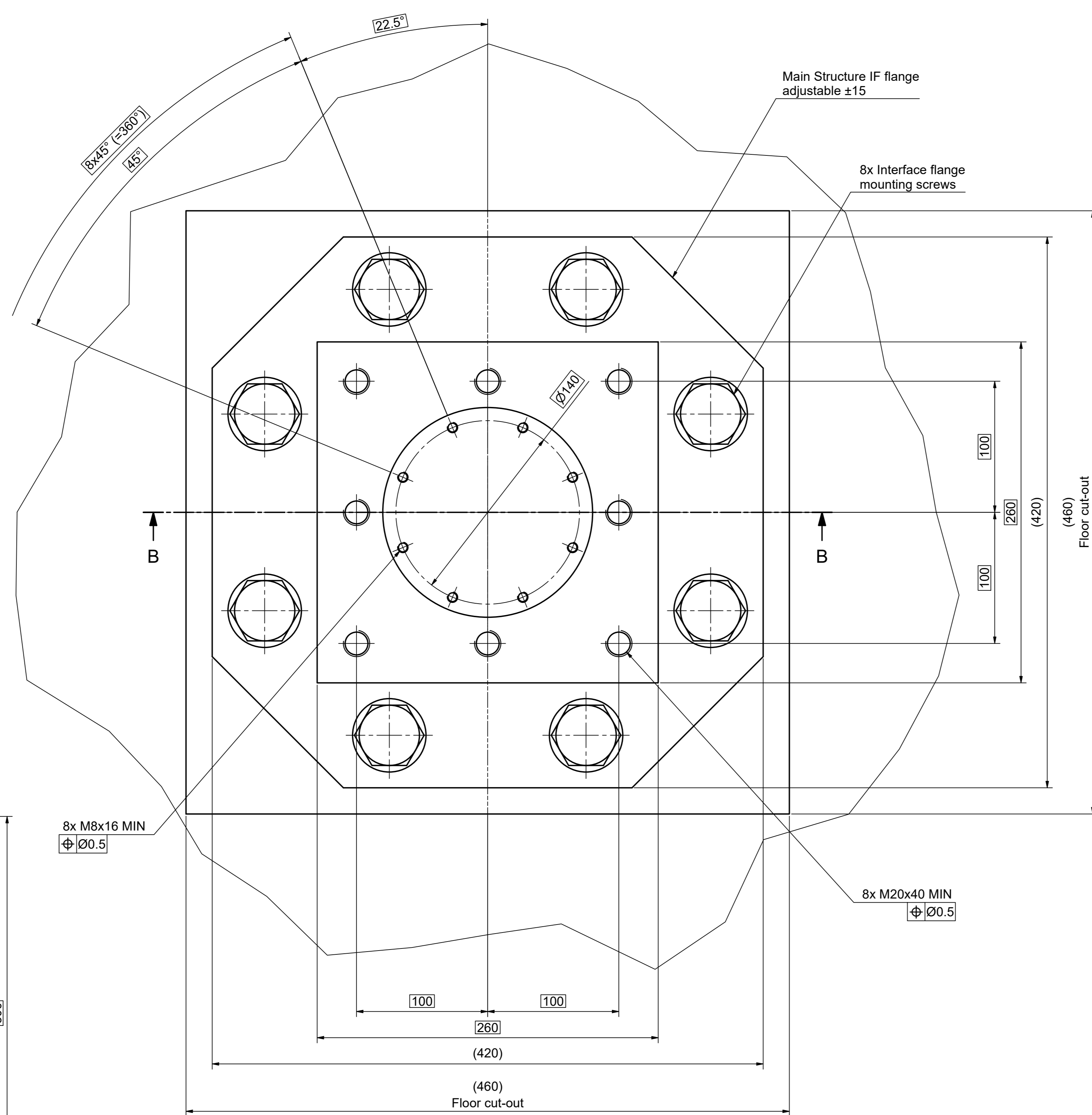

**X (1:2) Instrument Auxiliary Interface Flange**

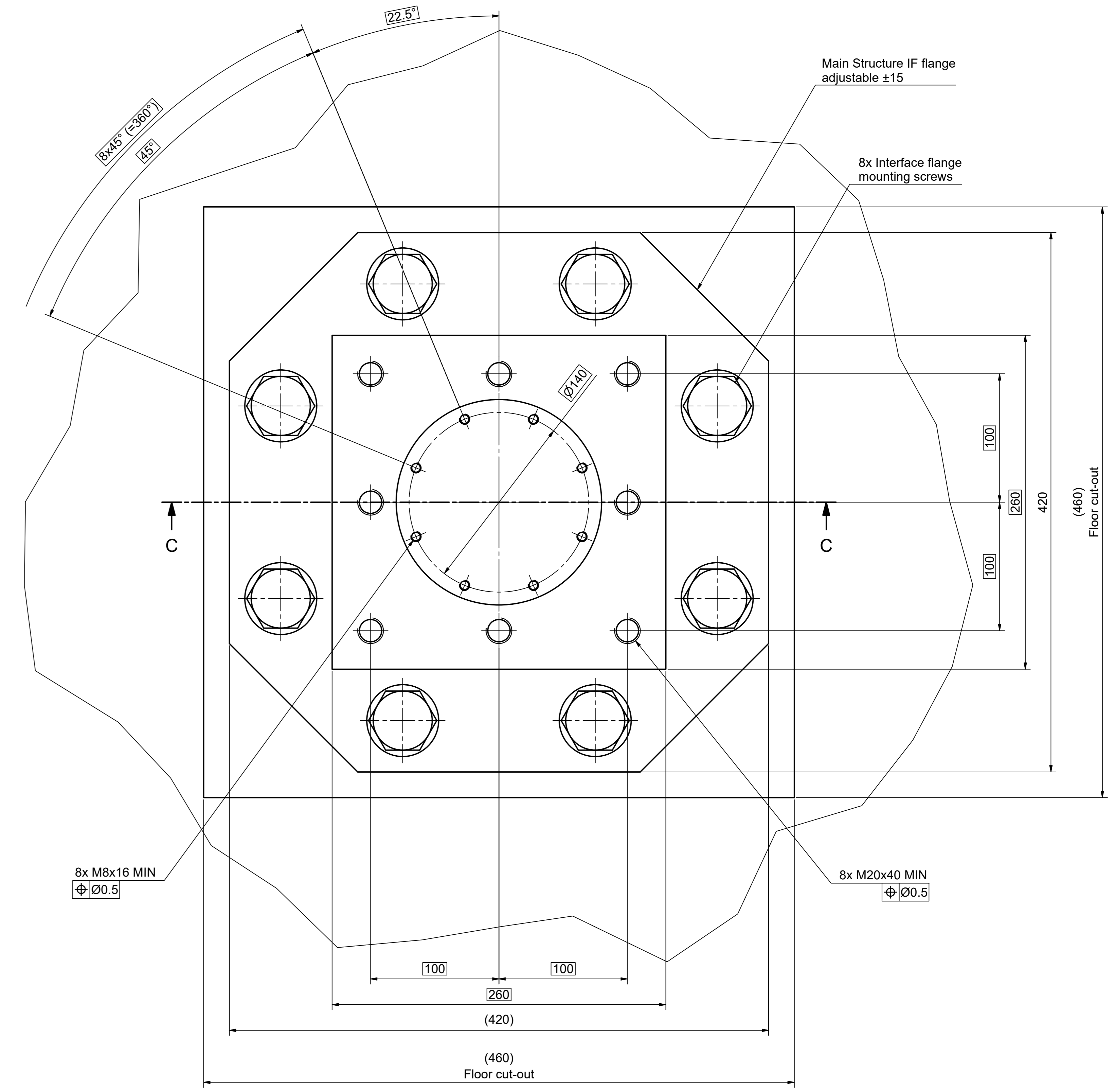

**Z (1:2) Prefocal Station Interface Flange**

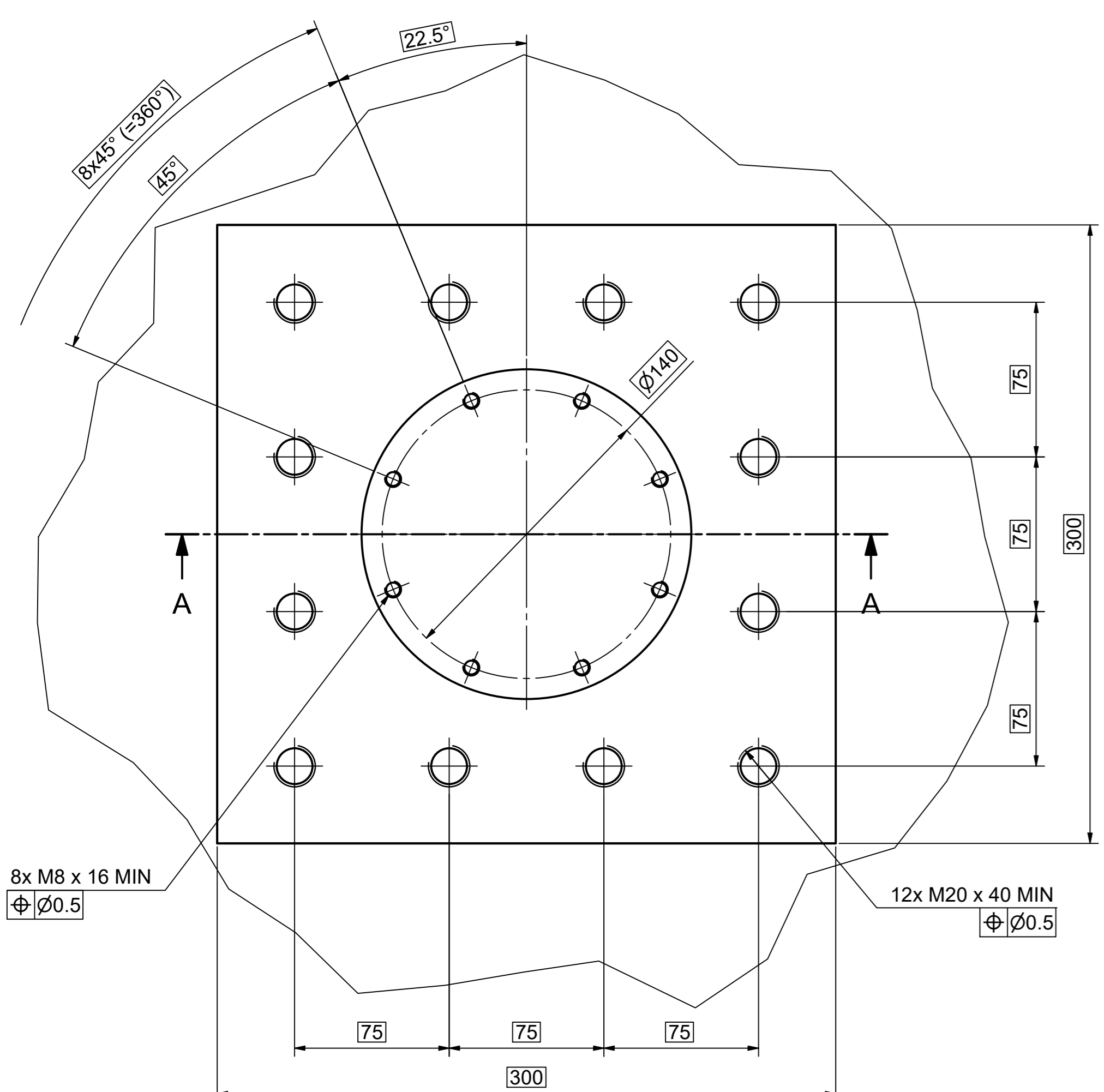

General Information	<p><b>DO NOT SCALE!</b> Drawing is for information only. All dimensions in mm unless otherwise stated.</p> <p>Designed By: mkrans Drawn By: mrdings Released By: cschmid</p> <p>Project Name: E-ELT Scale: 1:100</p>	<p>Material: Not applicable</p> <p>File: Additional Information</p> <p><b>Nasmyth Platform Interfaces</b> For Prefocal Station and Instruments</p> <p>Production: E-ELT Date: 2023-11-21</p>	<p>Sheet: 2 / 4 Revision: 3</p> <p>Released 2023-11-21 CAD-135139</p>
---------------------	--	--	---

3 Nasmyth Platform A Feedthroughs  
(1 : 100)

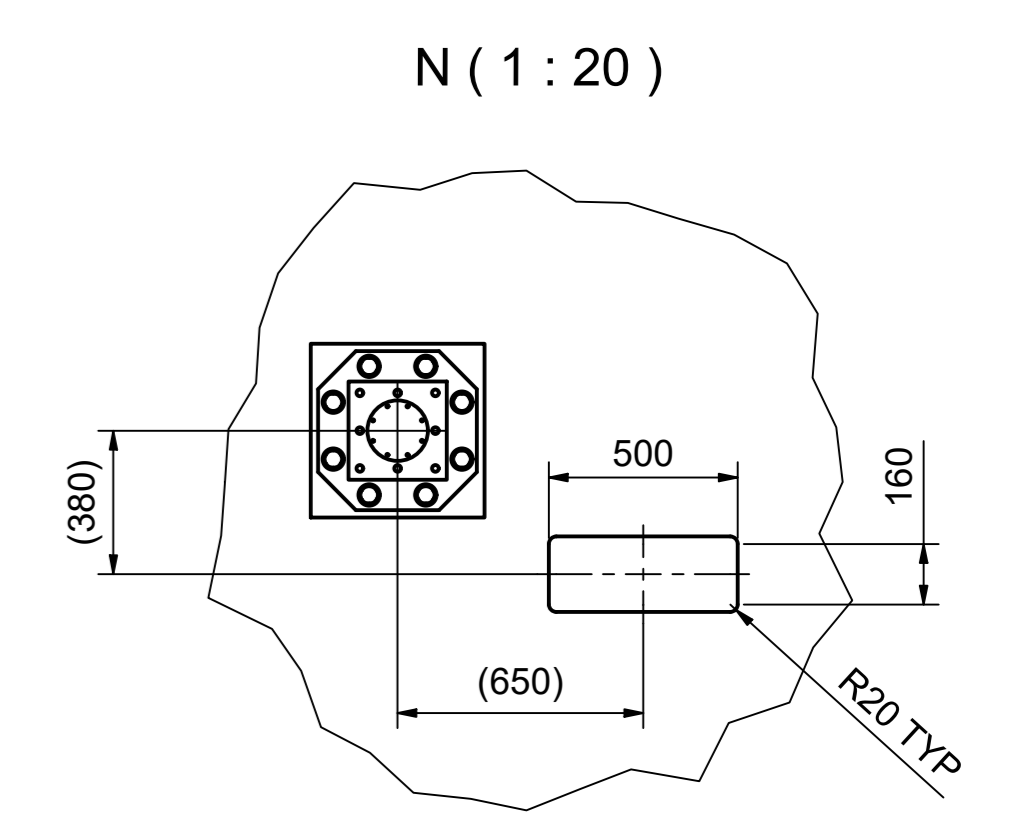
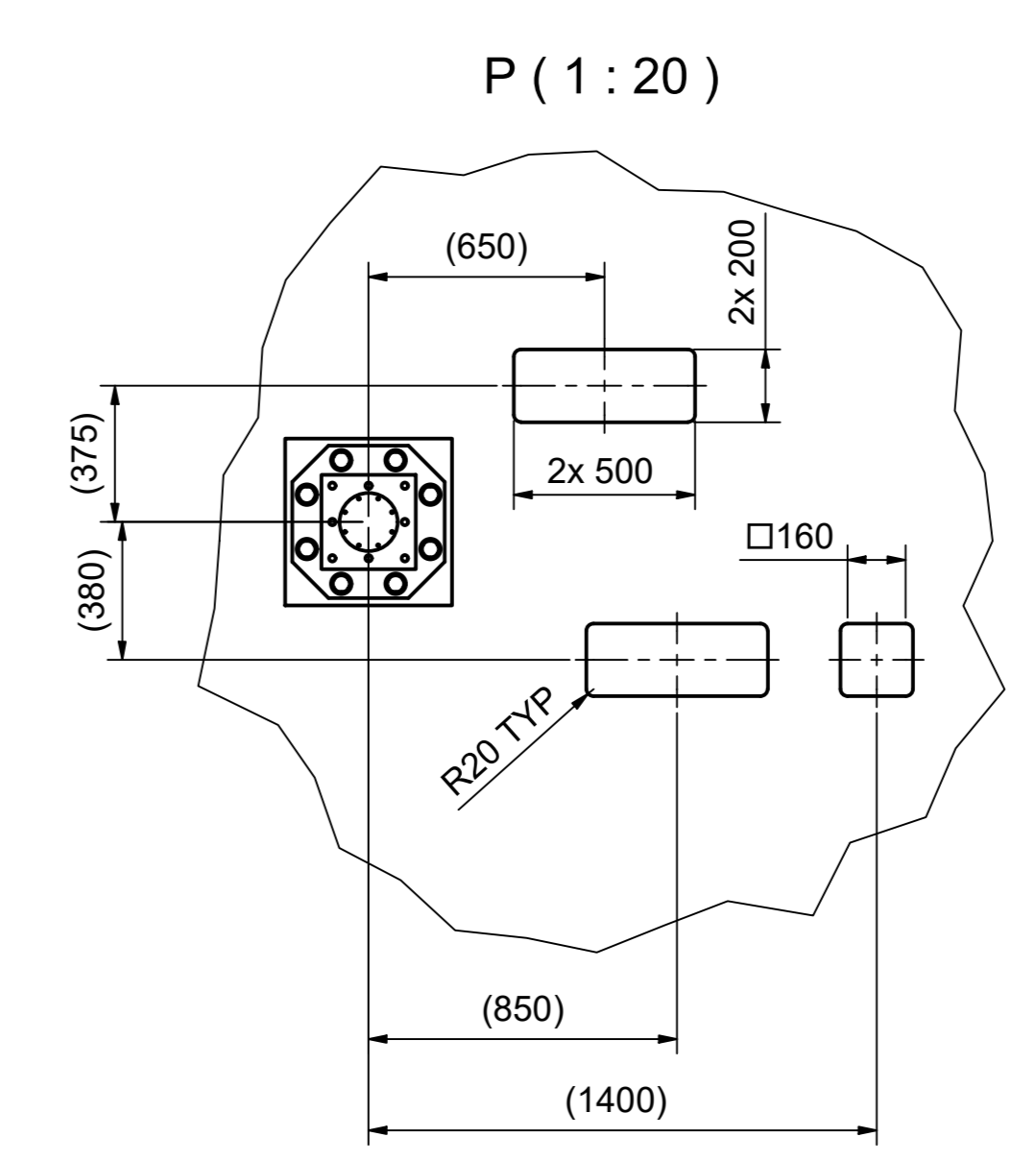
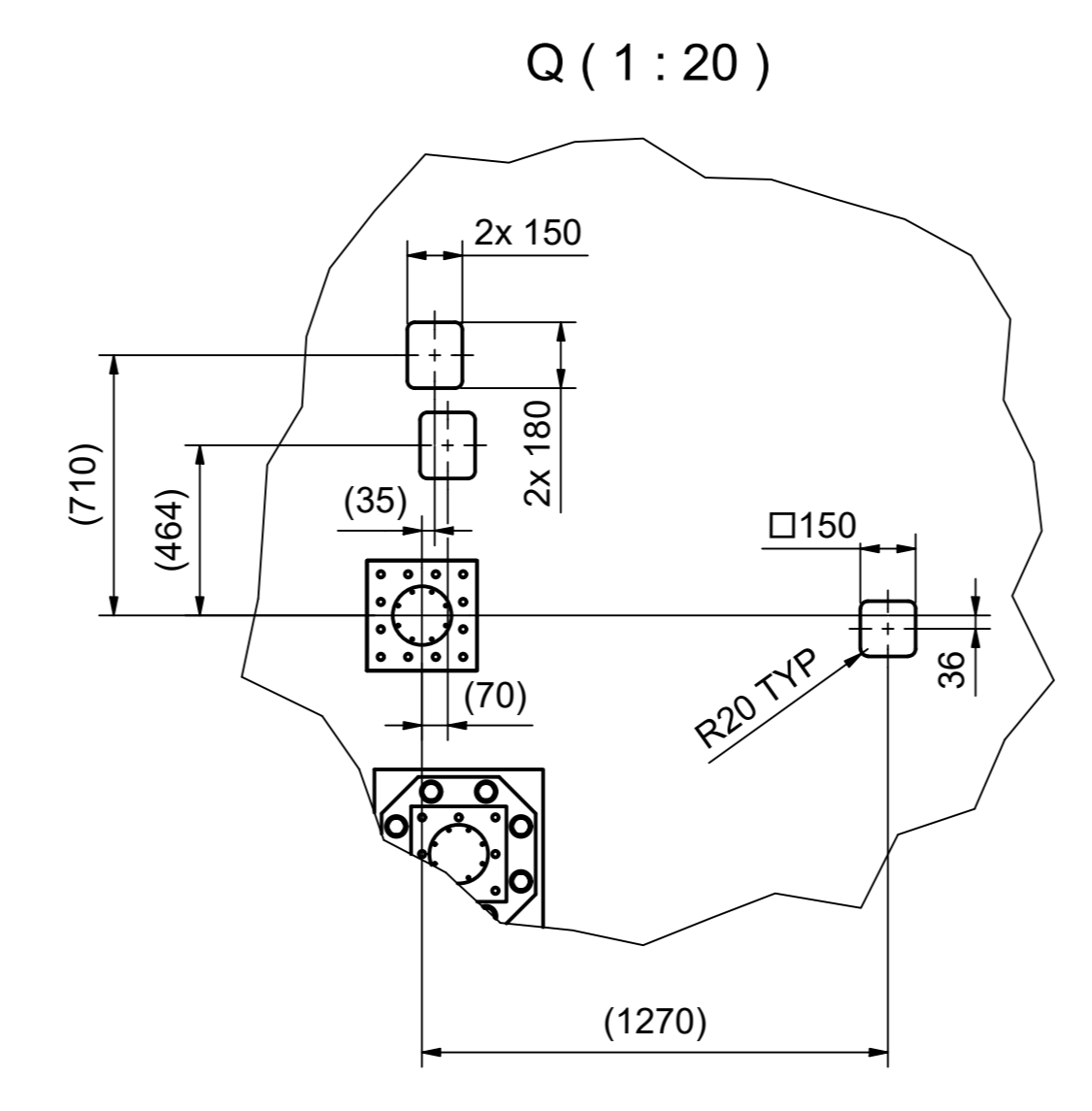
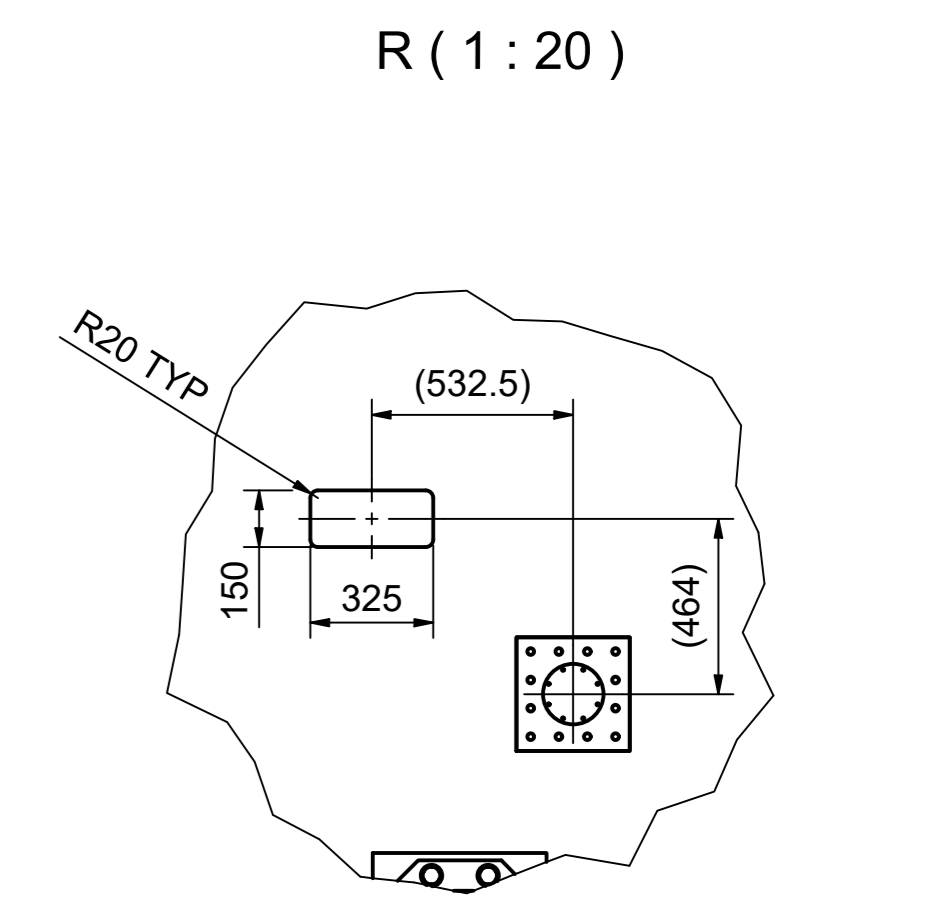
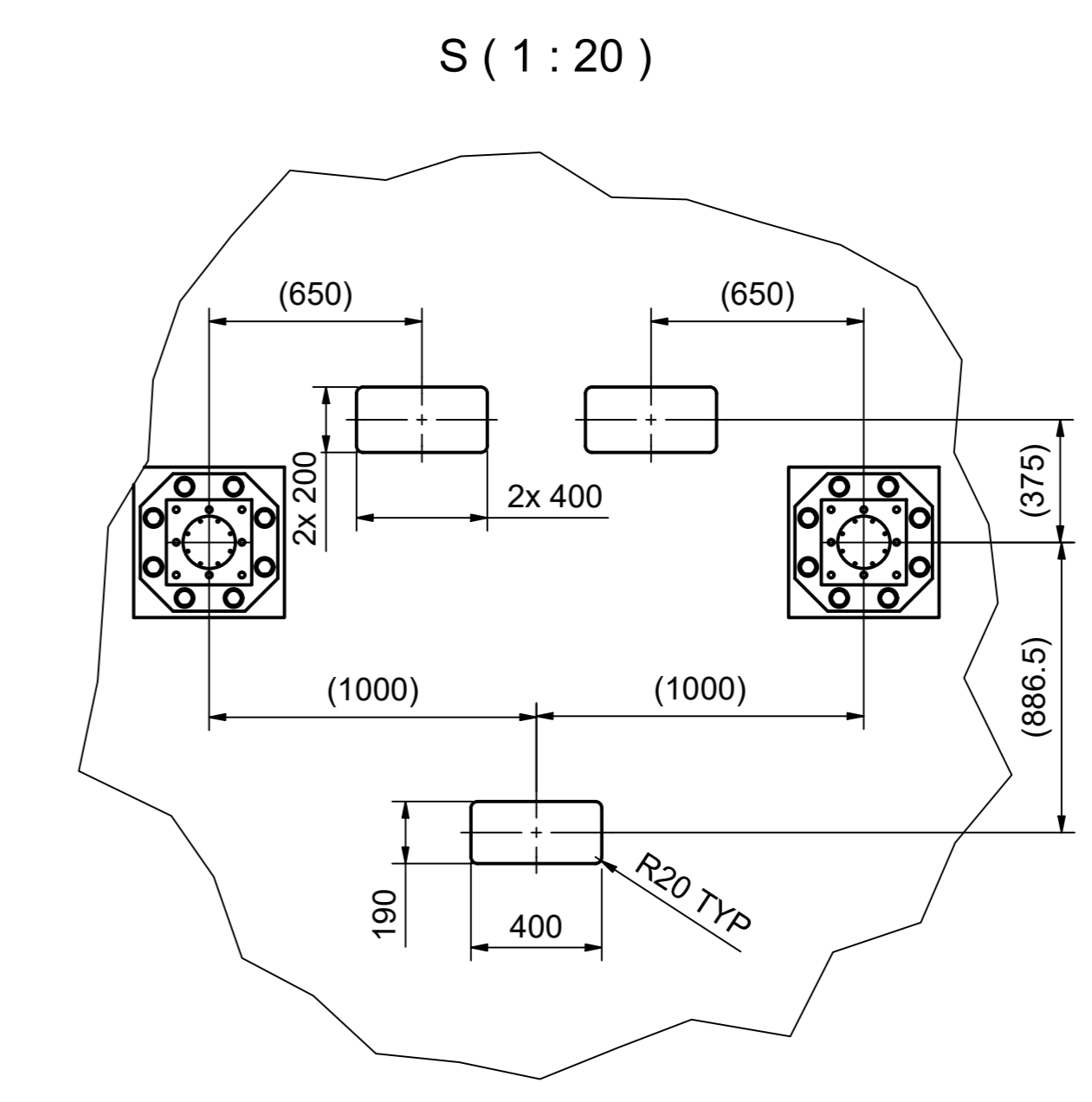
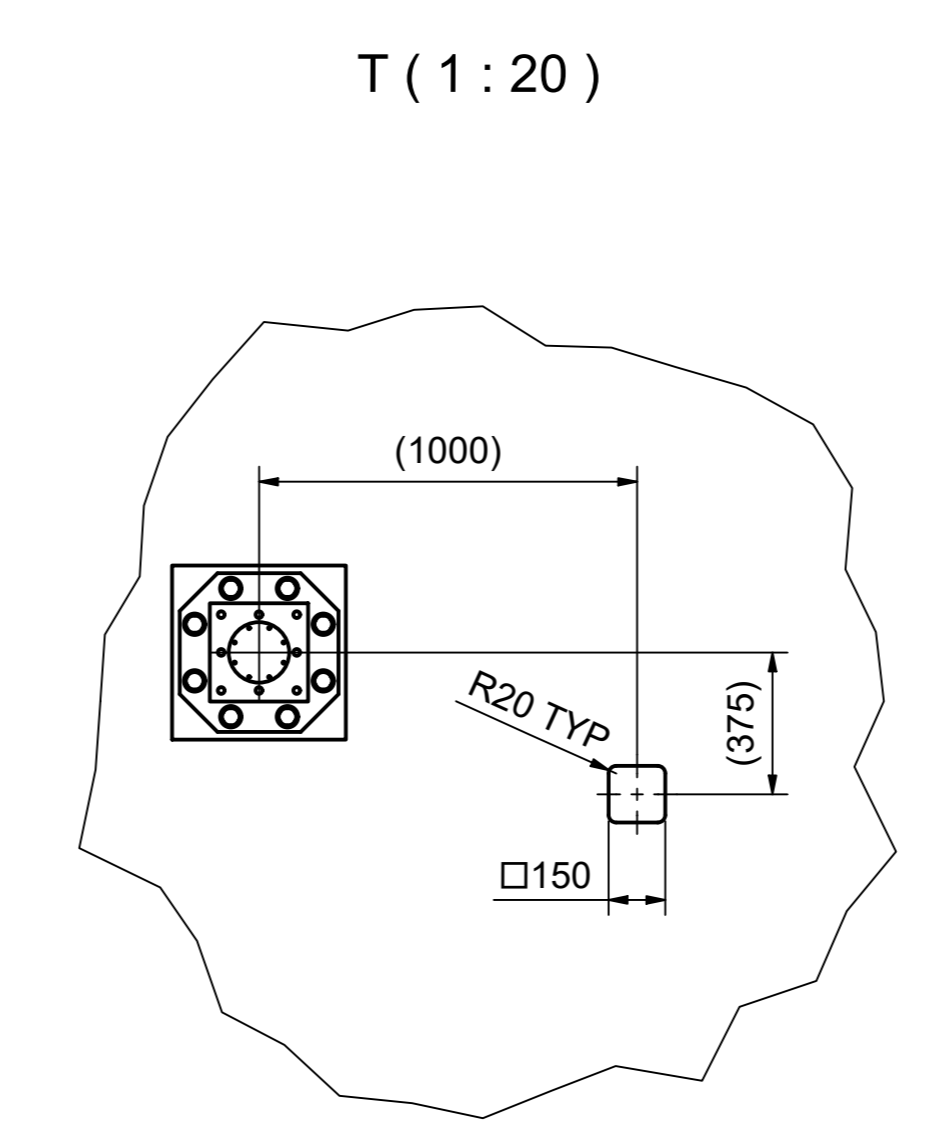
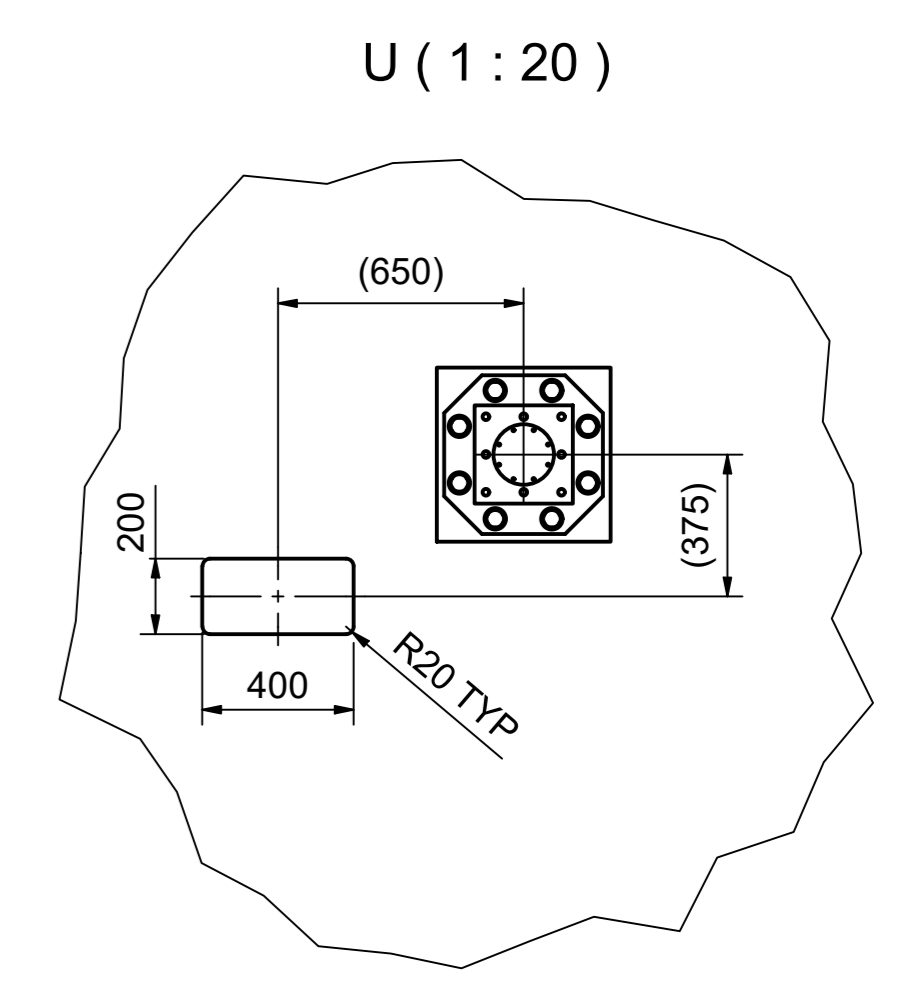
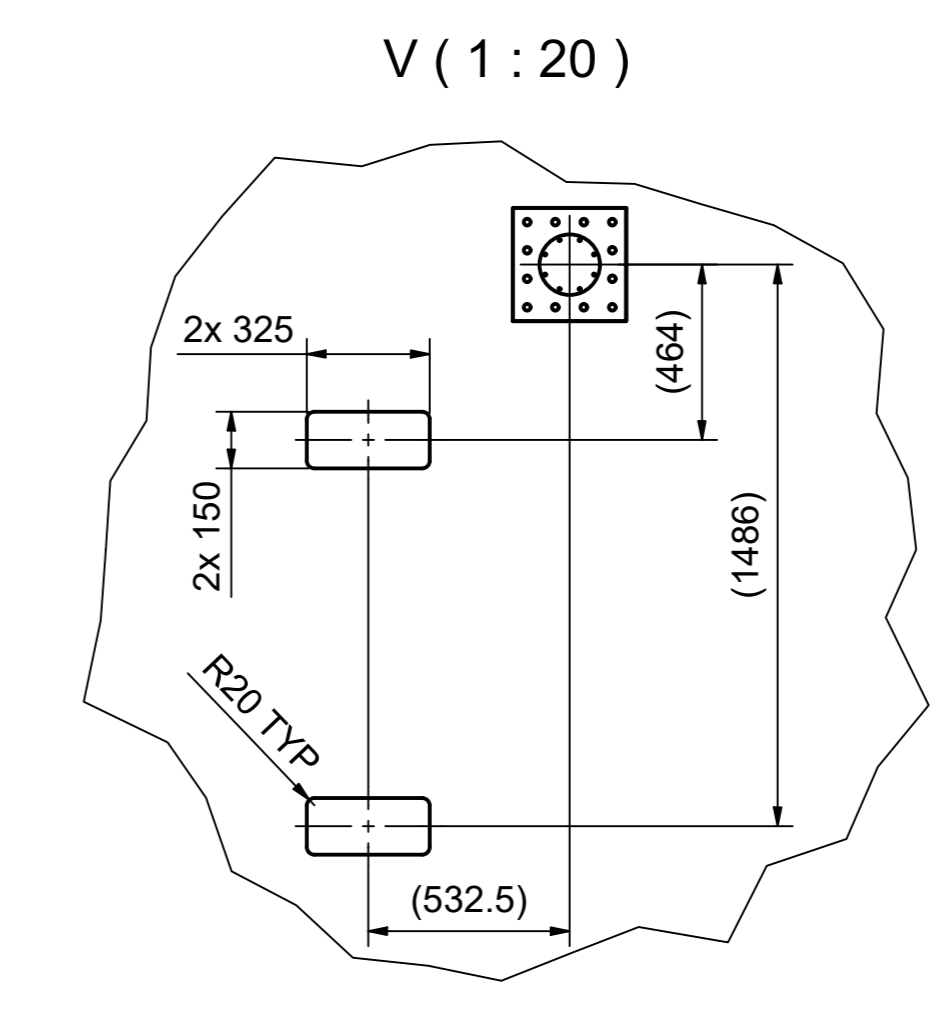
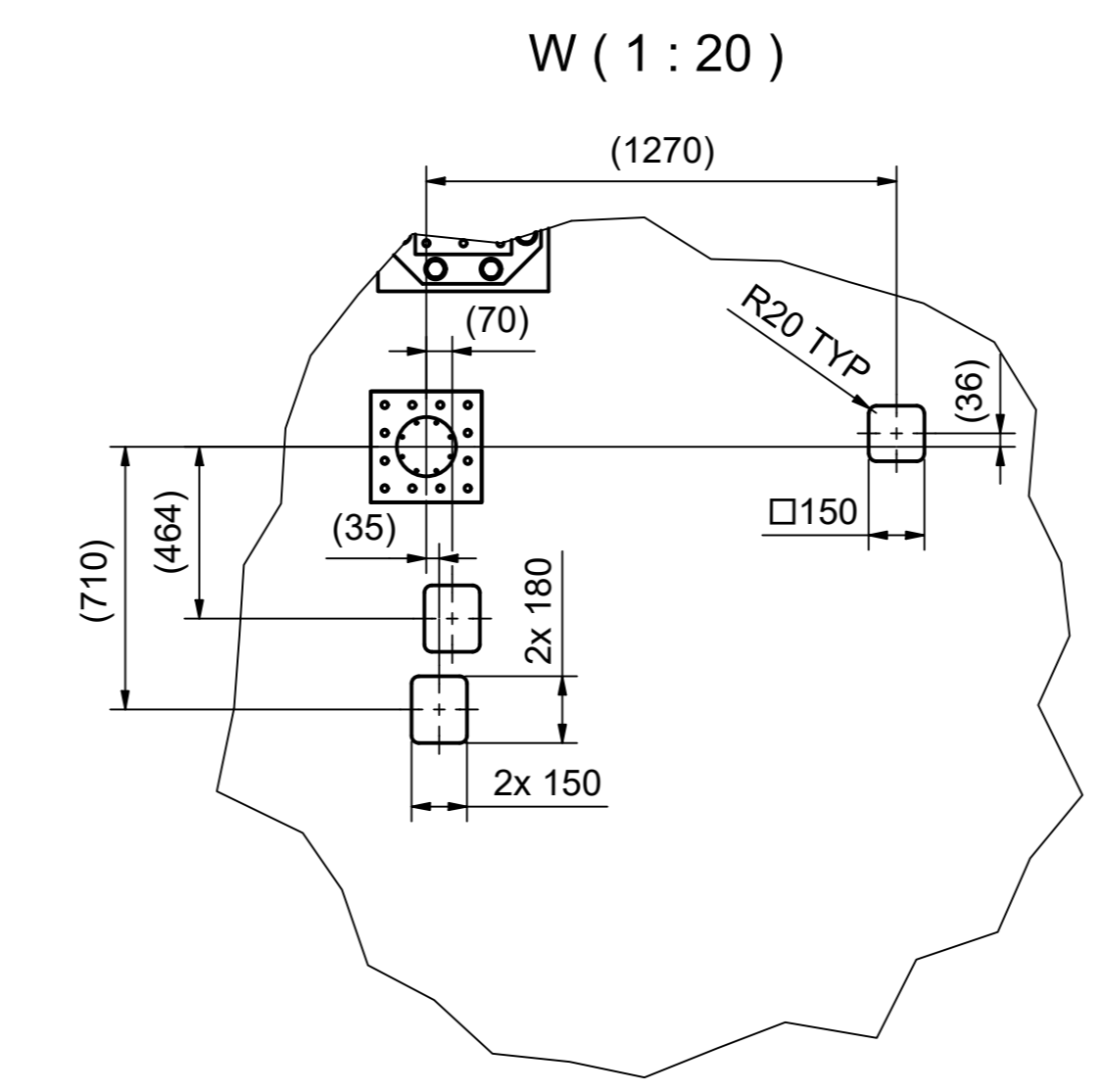
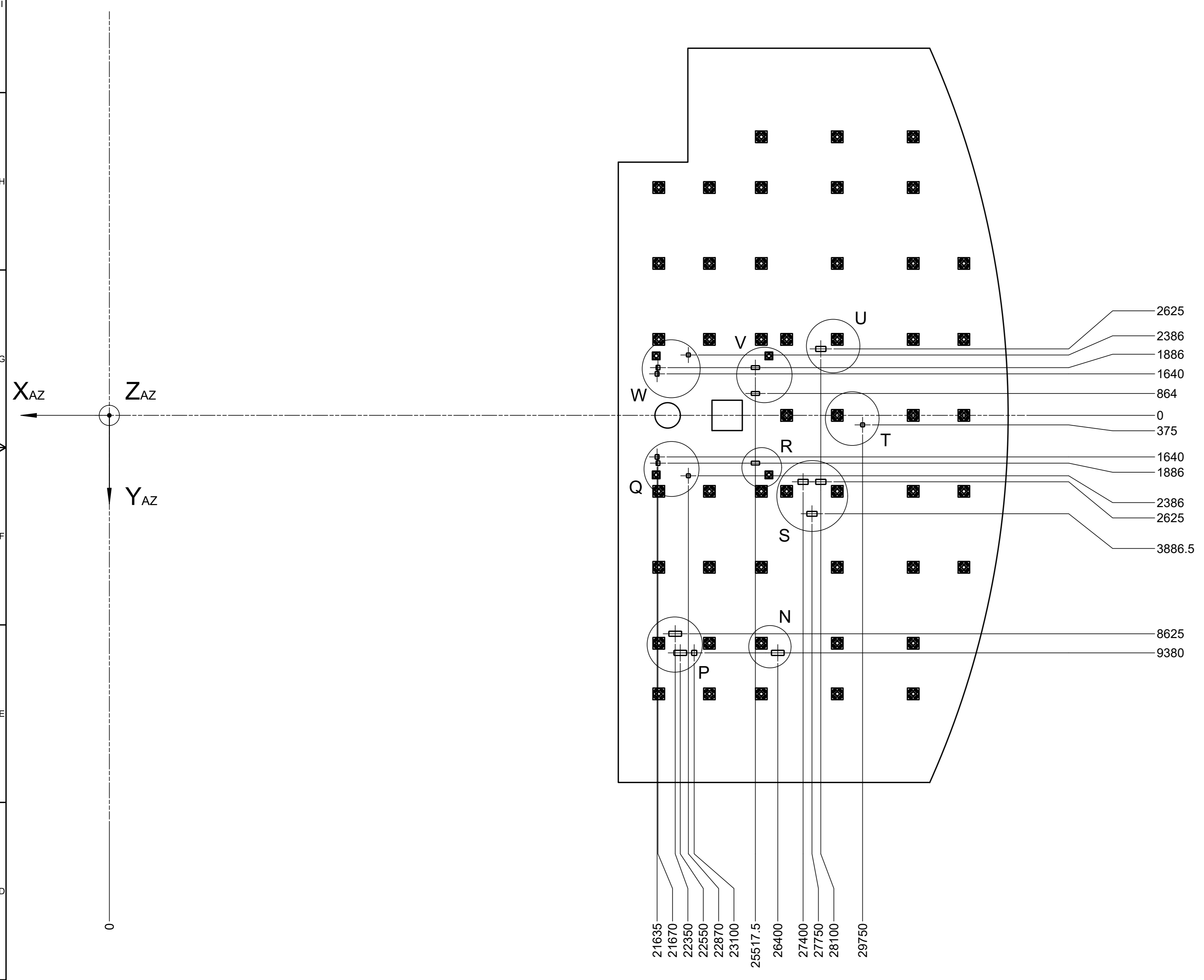

Notes:  
The information shown related to feedthroughs shall only be applicable to the Main Structure side of the interface.  
This information shall only be considered as reference for the Instrument side of the interface.  
Specific individual drawings shall define the information applicable to each individual instrument.

General Information	DO NOT SCALE! <small>Drawings are to be used for manufacturing purposes only. All dimensions in mm unless otherwise stated.</small>	Material Not applicable	Max. N/A
Designed By mkraus	Released By cschmid	For Prefocal Station and Instruments	Scale 1 : 100
Drawn By mrdings	Released By E-ELT	Production E-ELT	Sheet 3 / 4
www.eso.org	Released	Date 2023-11-21	Document ID CAD-135139

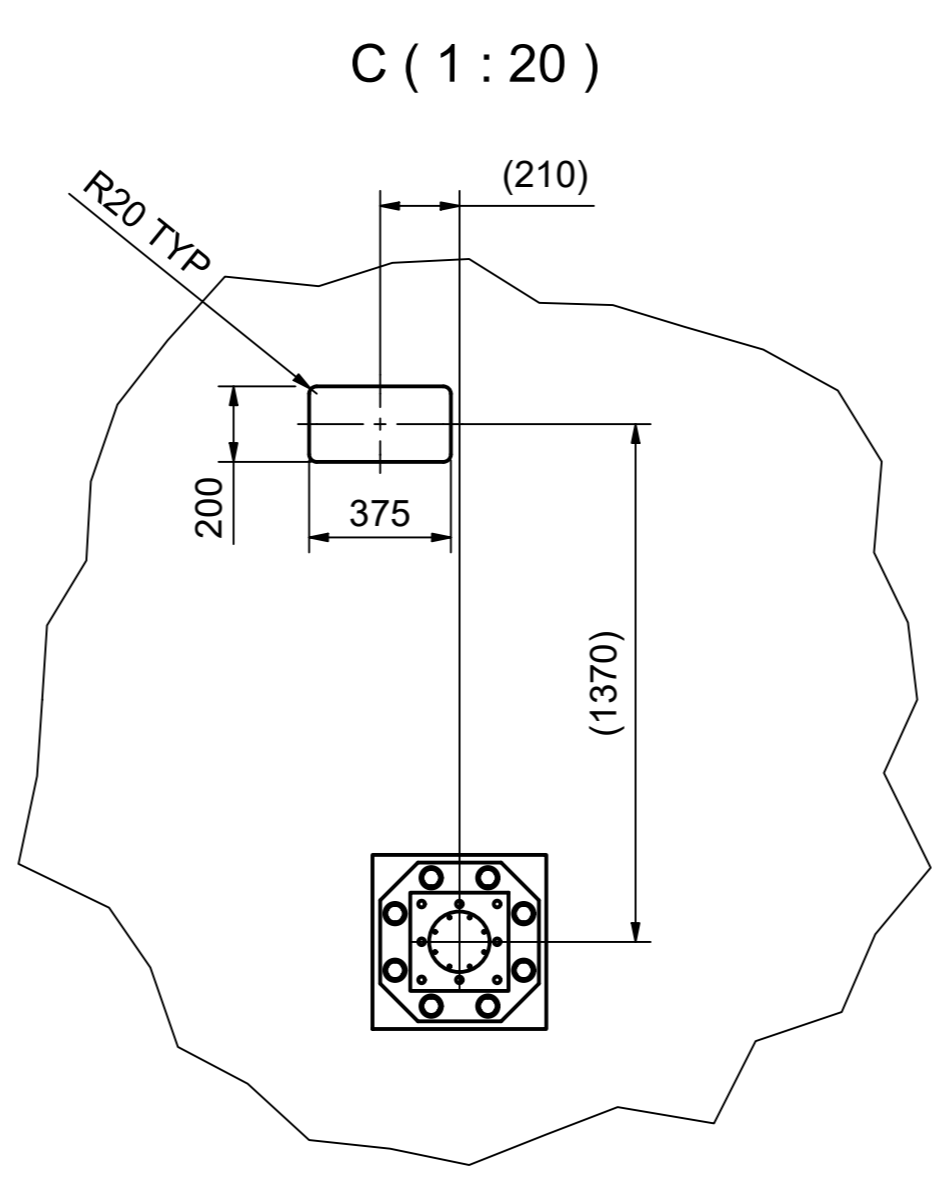
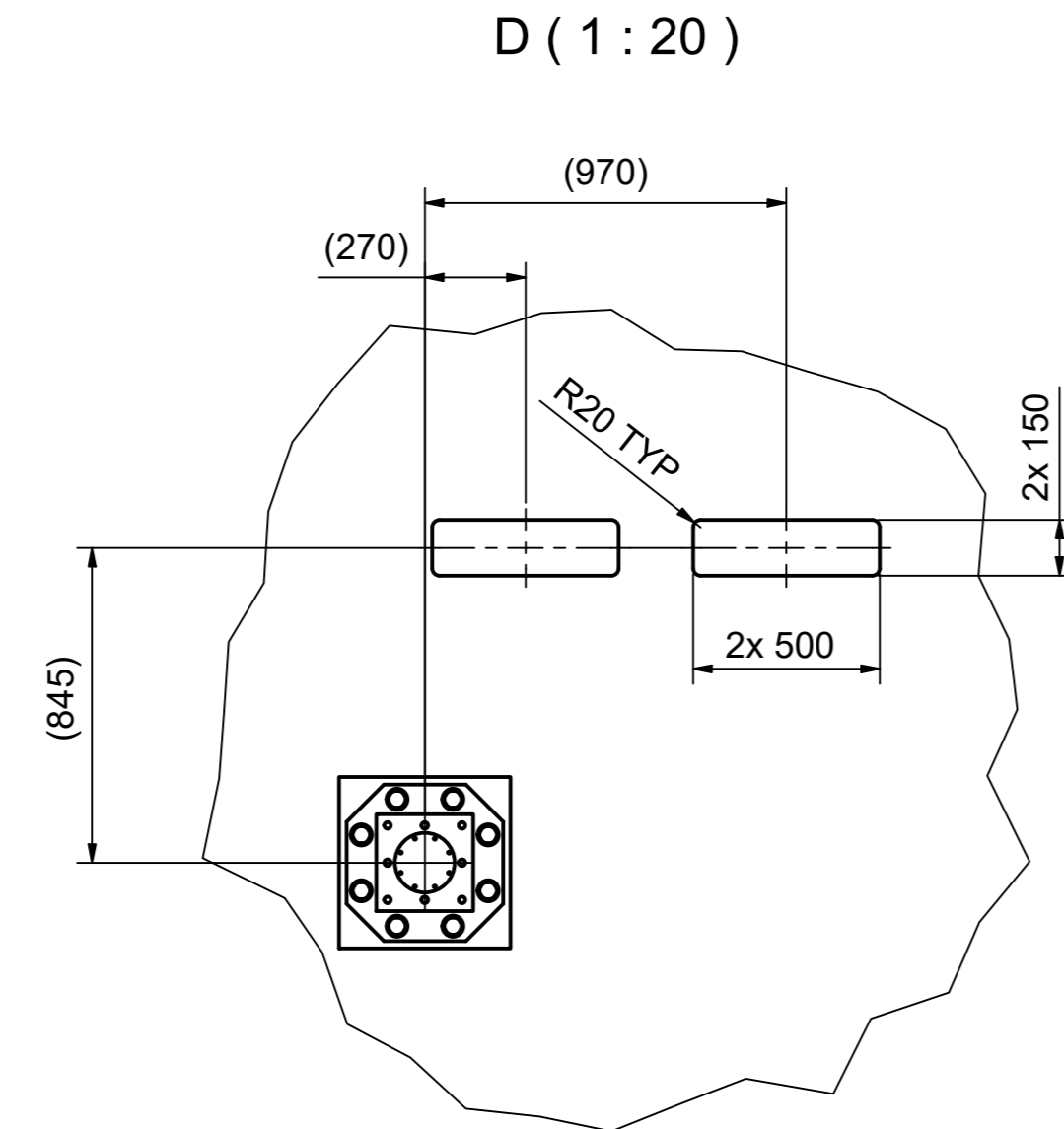
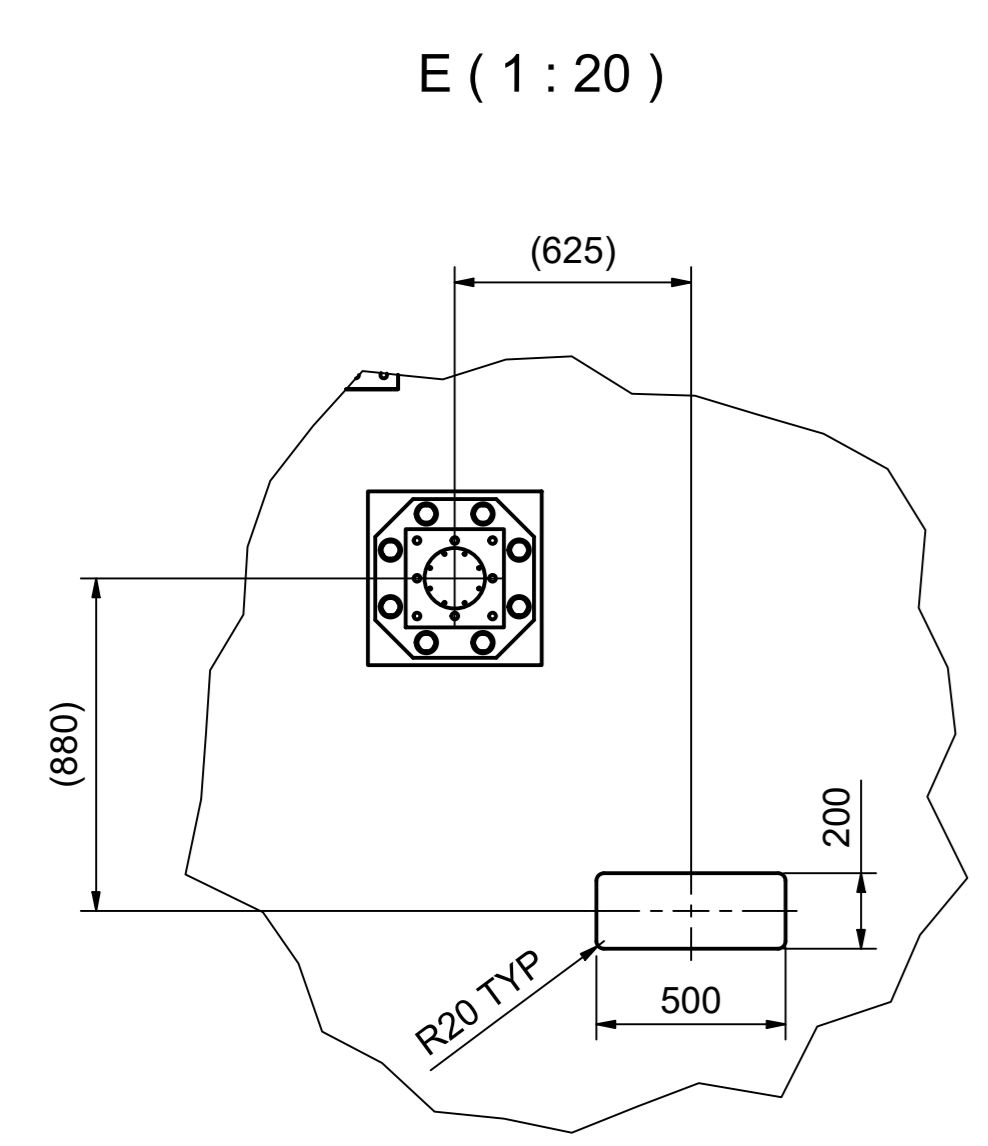
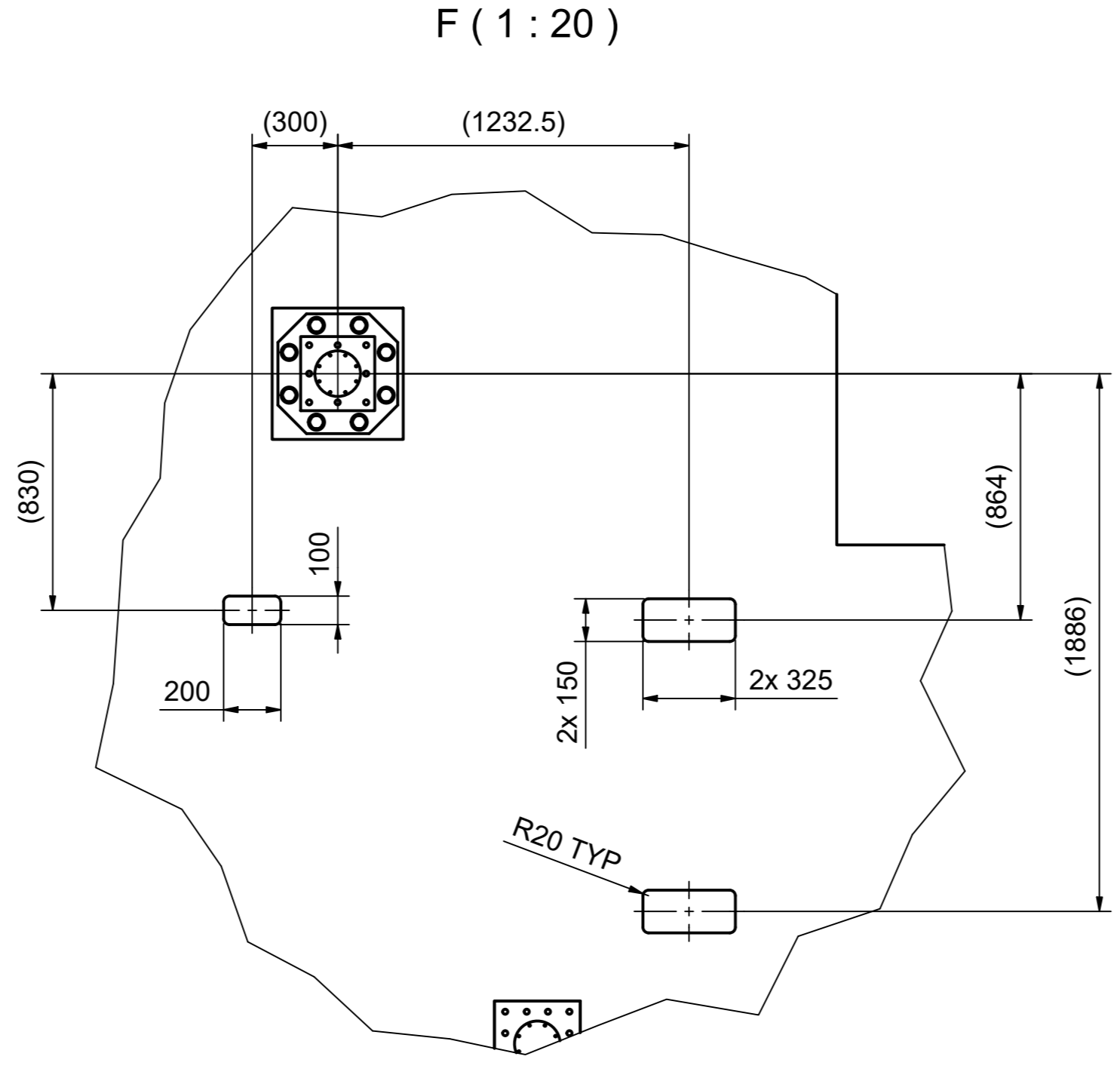
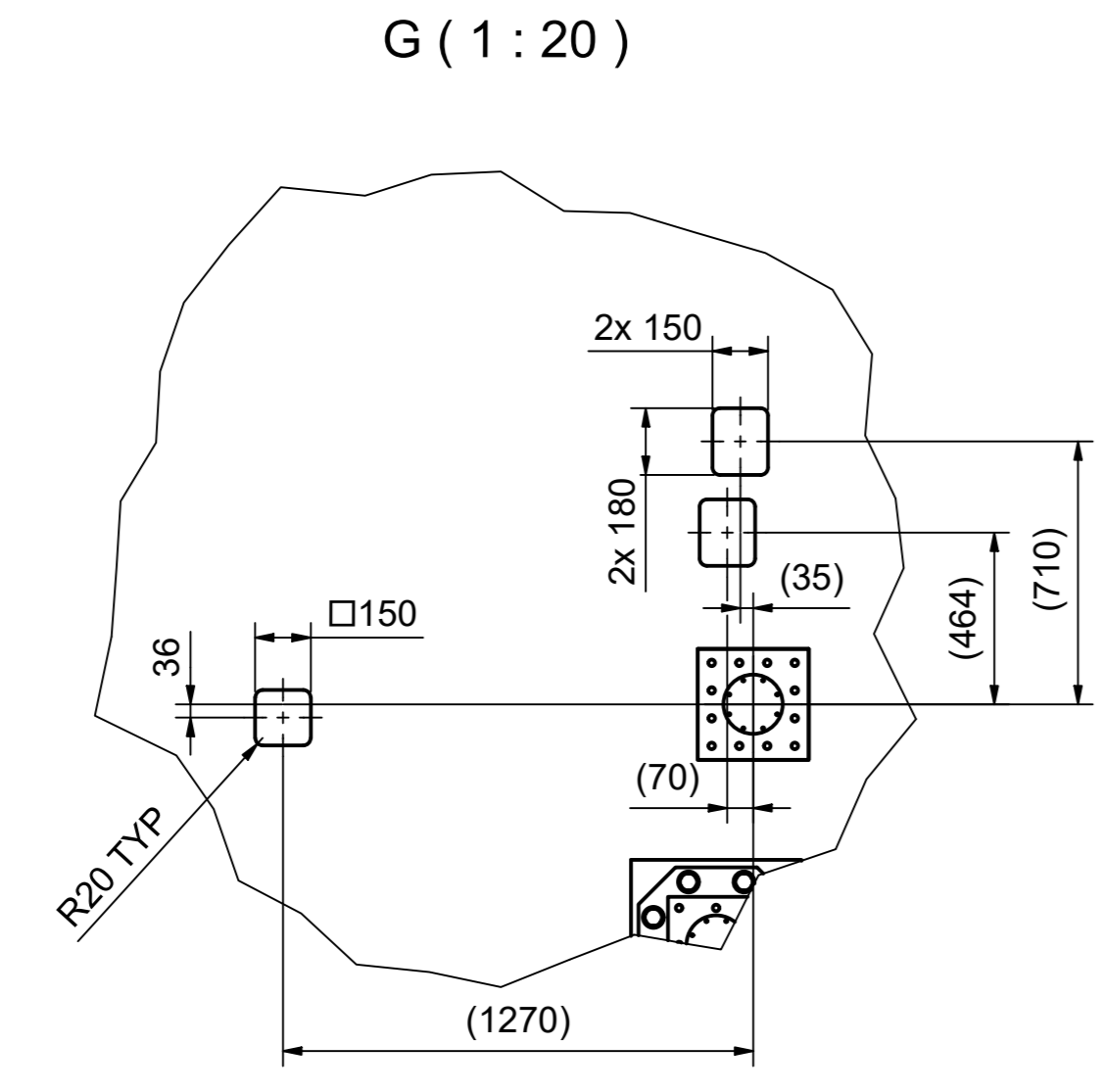
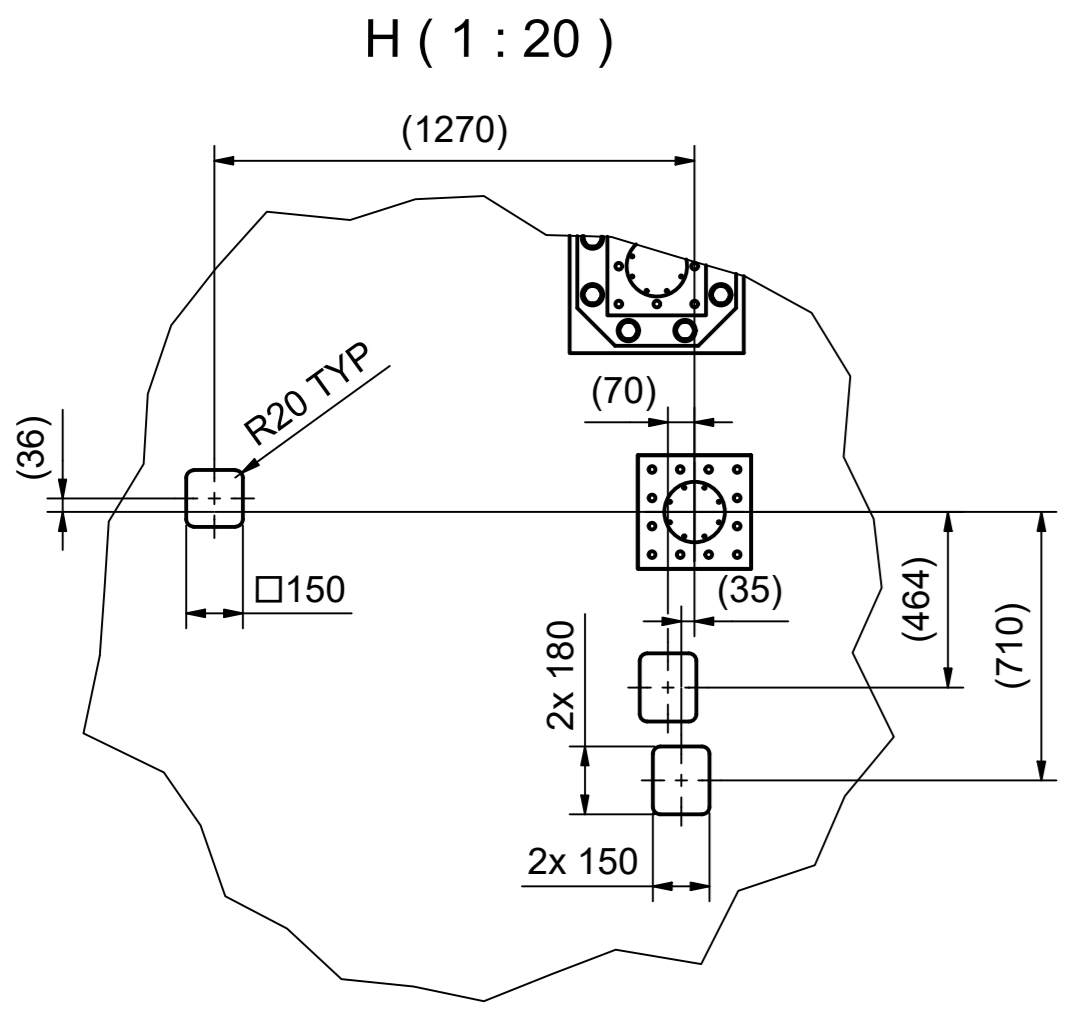
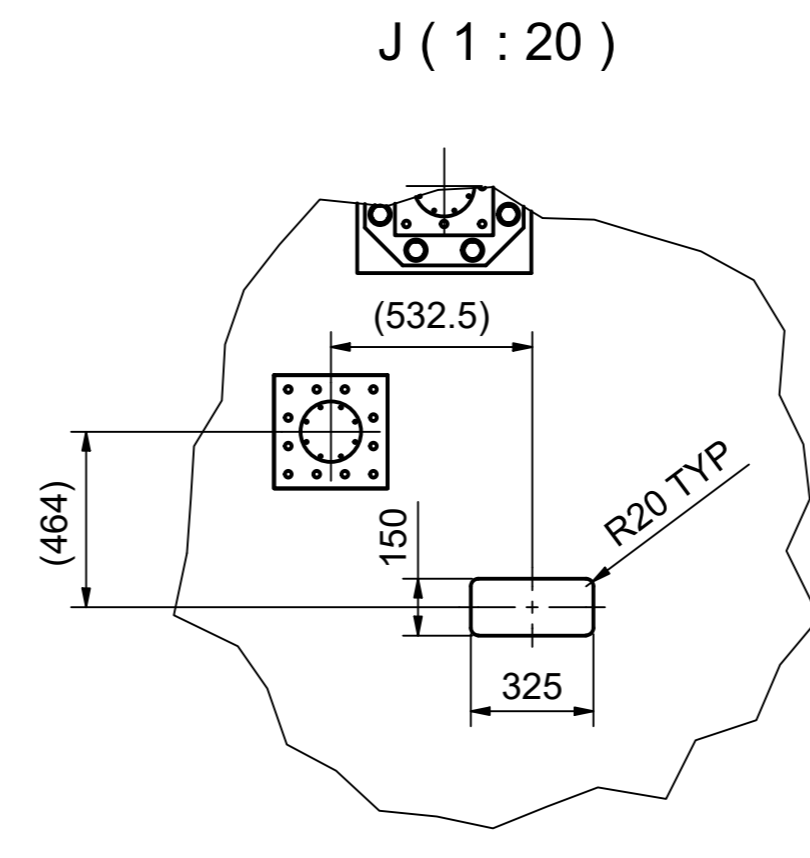
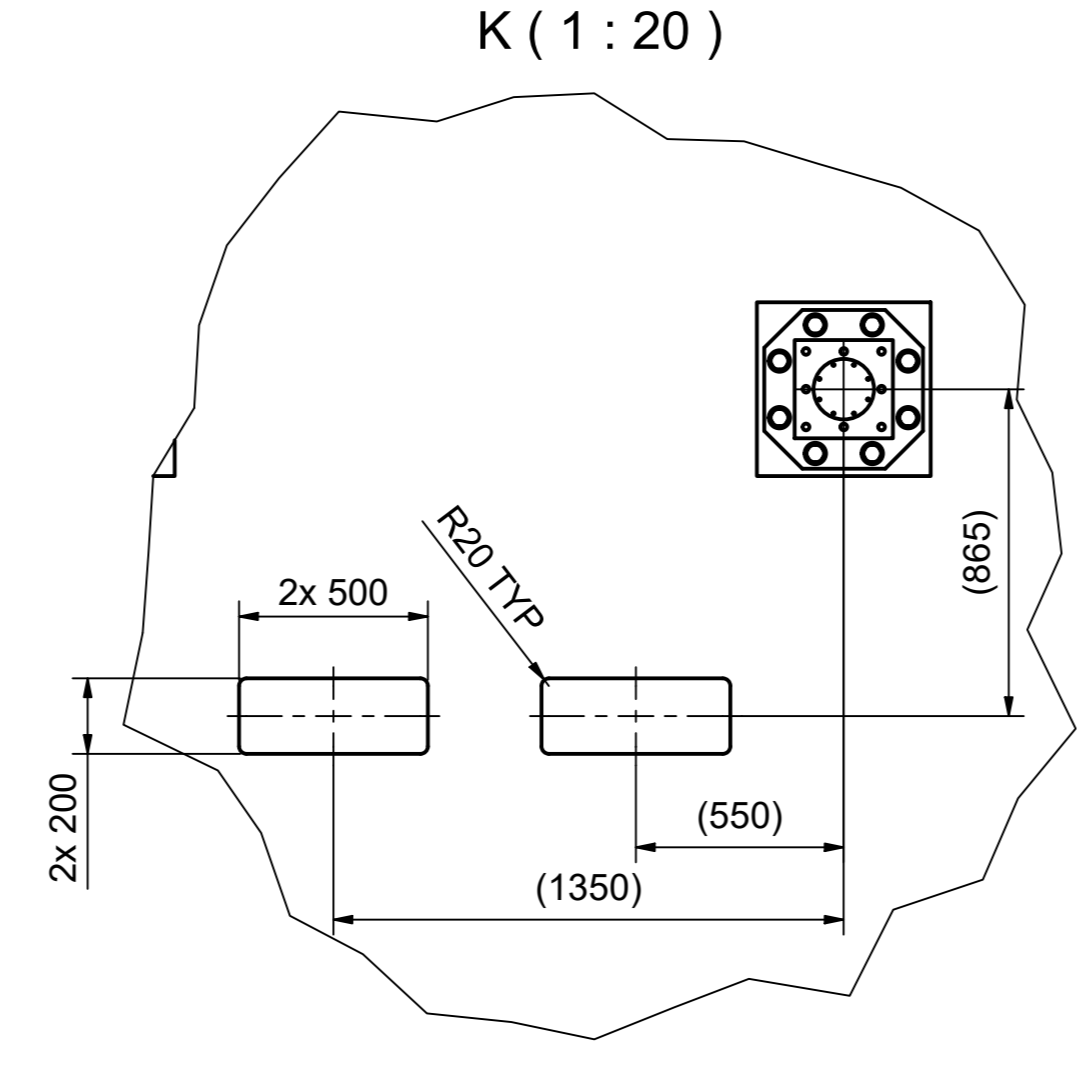
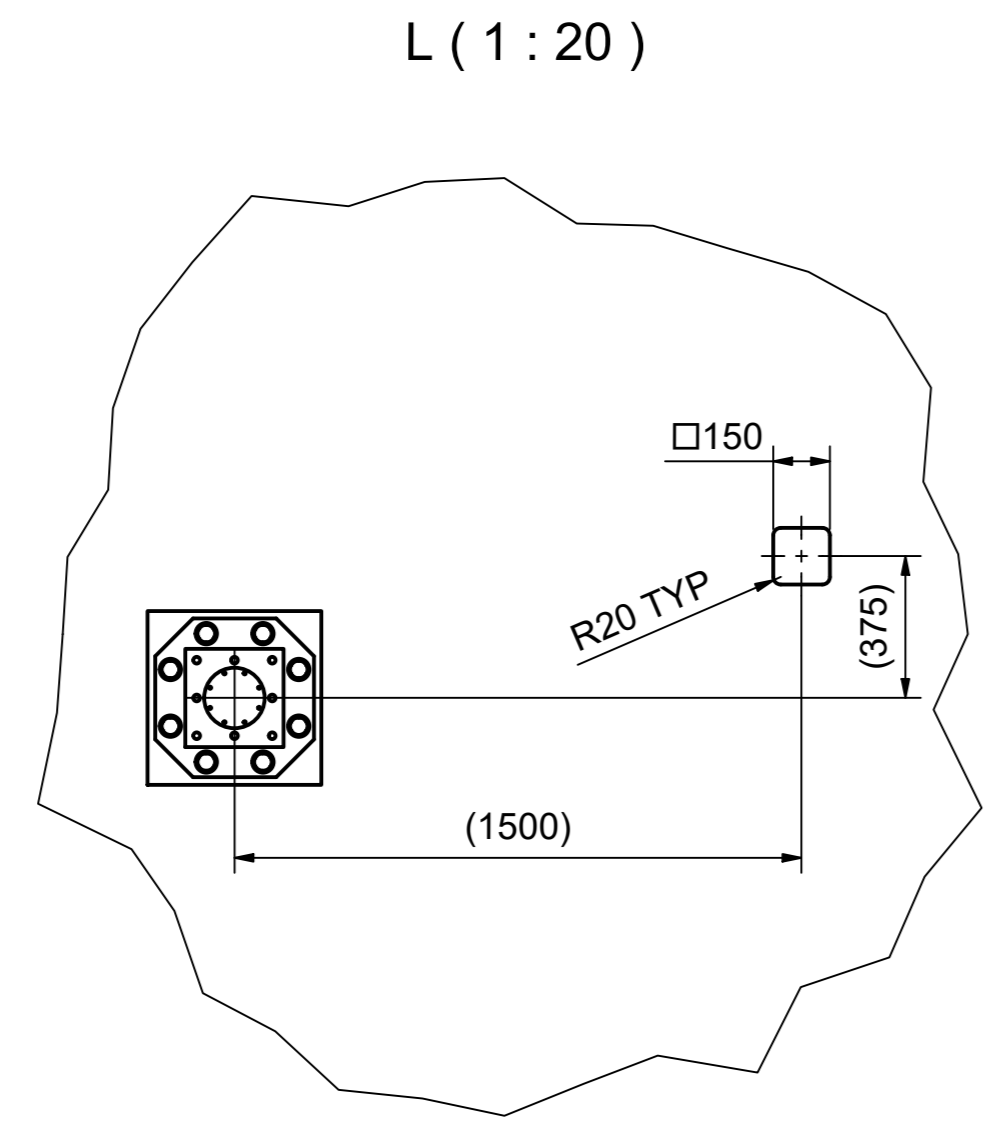
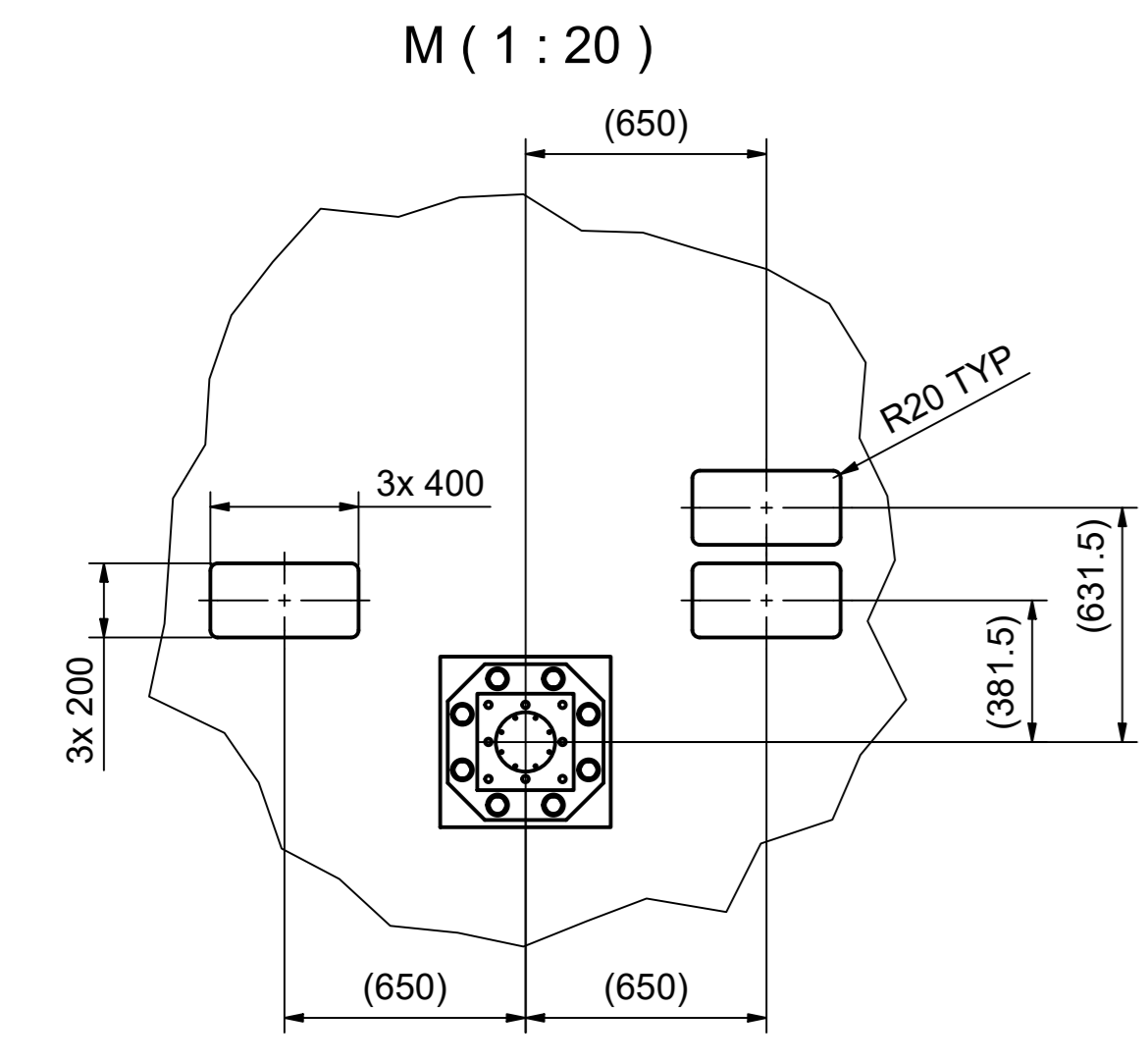

**3 Nasmyth Platform B Feedthroughs (1 : 100)**

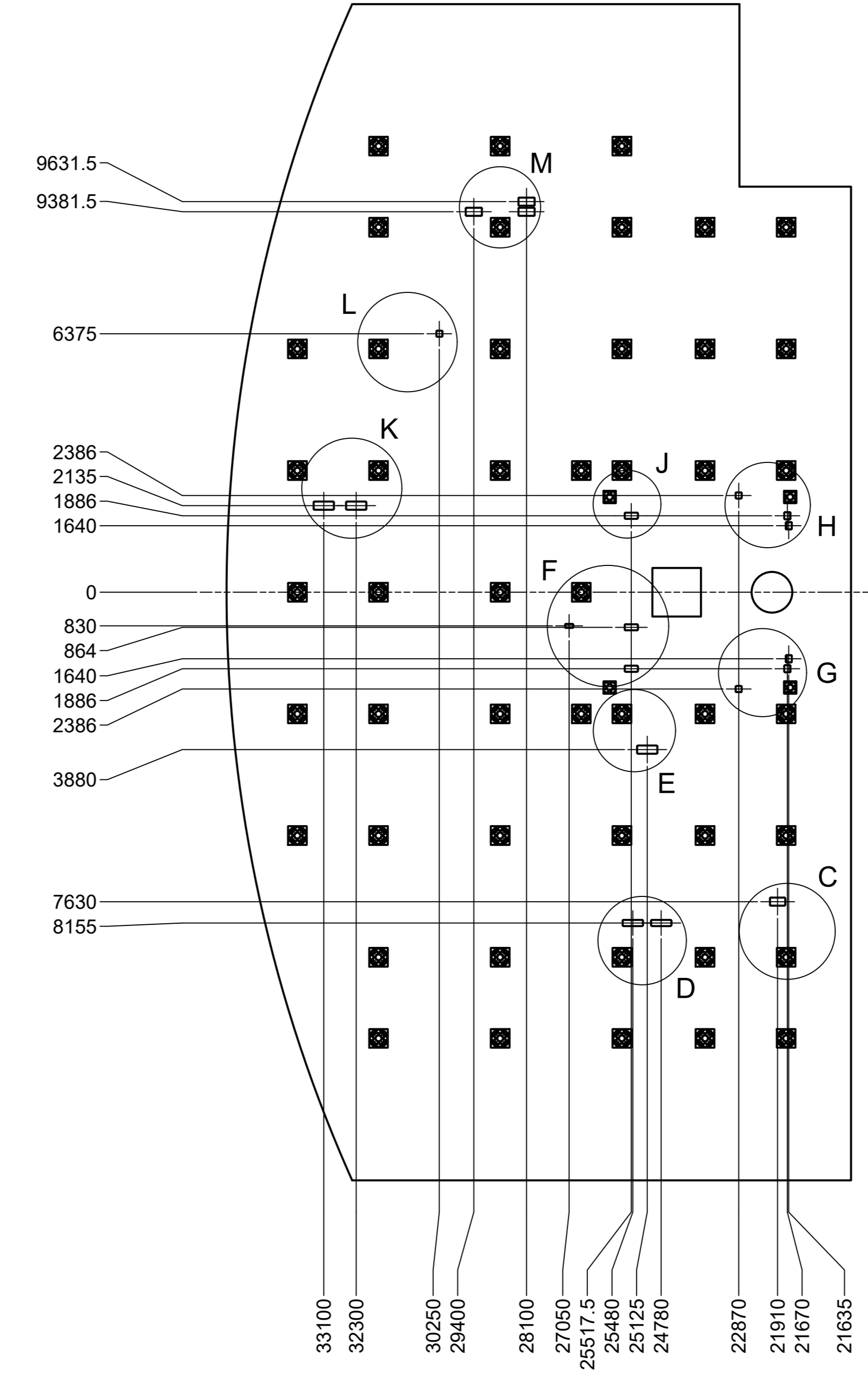

**Notes:**  
 The information shown related to feedthroughs shall only be applicable to the Main Structure side of the interface.  
 This information shall only be considered as reference for the Instrument side of the interface.  
 Specific individual drawings shall define the information applicable to each individual instrument.

General Comments	DO NOT SCALE! Drawing prepared by ESO/ESD/ESD All dimensions in mm unless otherwise stated	Material	Not applicable	Max.	N/A
Designed By	mkraus	File Additional Information	Nasmyth Platform Interfaces		
Drawn By	mdings	For Prefocal Station and Instruments			
Released By	cschmid	Production No.	E-ELT	Scale	1 : 100
ESD Project	E-ELT	Revision	100	Sheet	4 / 4
State	RELEASED	Date	2023-11-21	Document ID	CAD-135139
					3